

GENERAL TOLERANCE (TERMINAL)								GENERAL TOLERANCE (HOUSING)							USED ON
1 MAX	5 MAX	10 MAX	20 MAX	45 MAX	45 VR	ANGLE	ECCENT	10 MAX	50 MAX	100 MAX	250 MAX	250 VR	ANGLE	ECCENT	
±0.1	±0.15	±0.2	±0.25	±0.3	±0.5	±30'	0.1	±0.2	±0.3	±0.55	±0.95	±1.4	±30'	0.1	

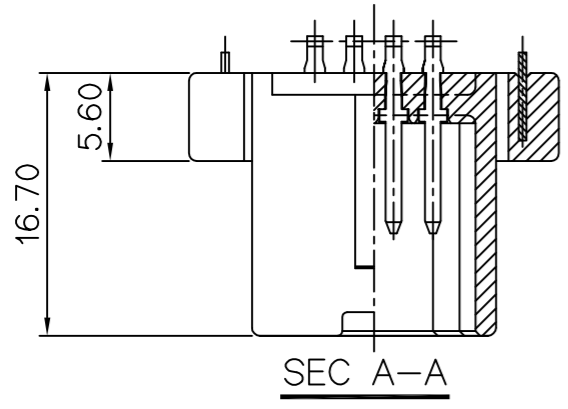

SEC A-A

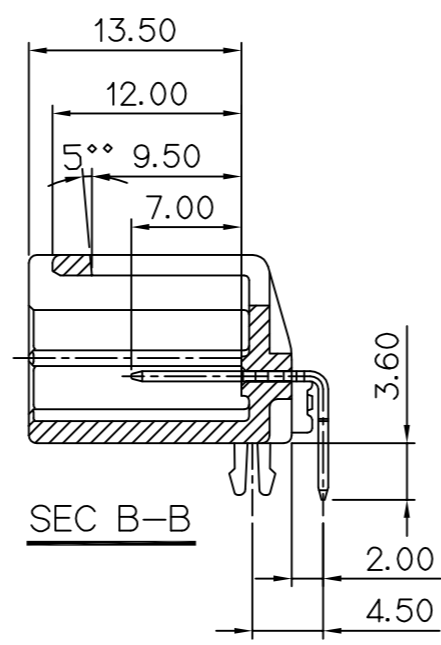
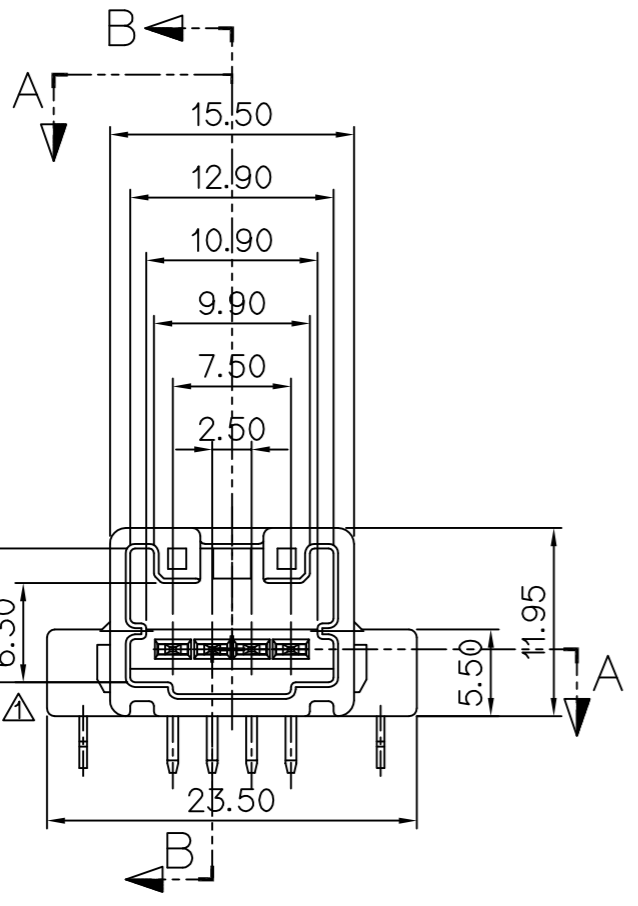
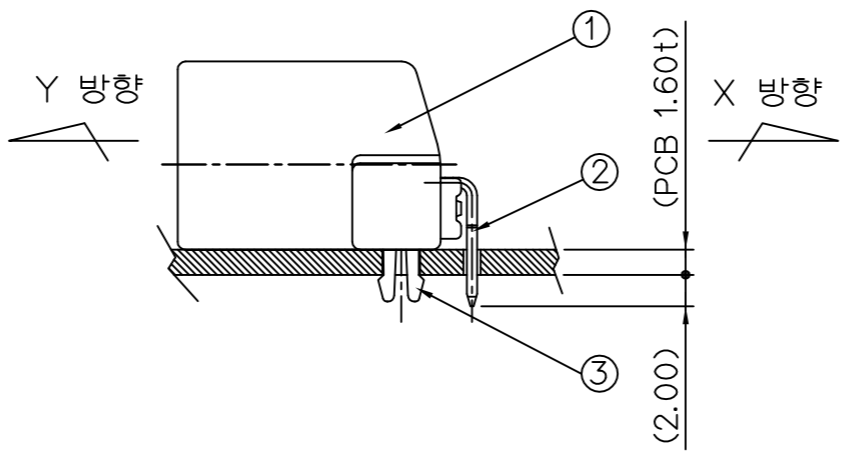

SEC B-B

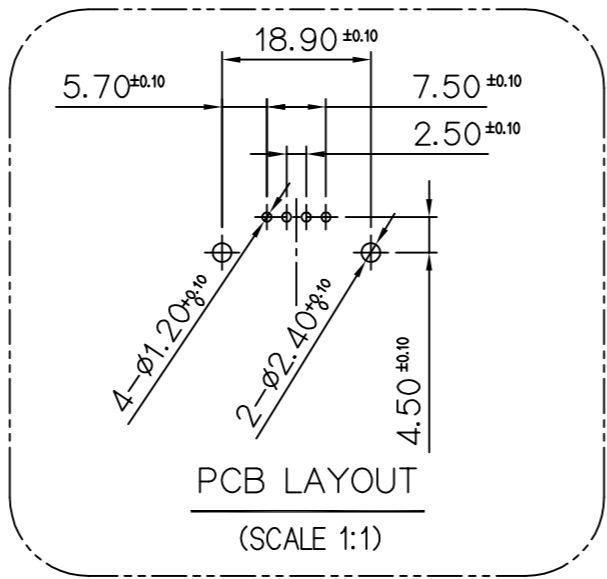
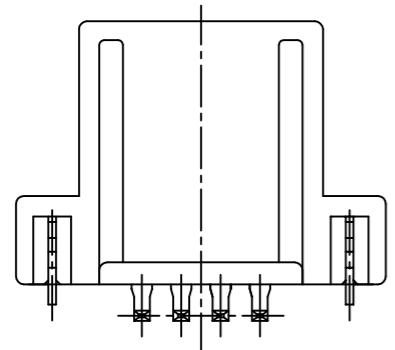
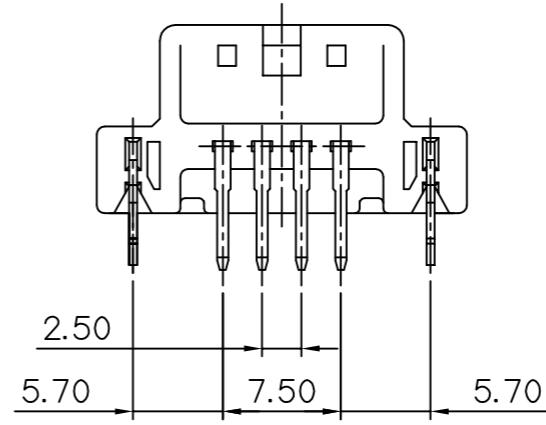

PCB LAYOUT (SCALE 1:1)

NOTE

1. 지시하지 않은 반경 R은 0.3로 한다
2. 기능상 유해한 BURR등 변형이 없을것.
3. 적용 PLUG HOUSING : MG652999
4. 본 제품은 ES-91500 항을 만족할것.
5. TERMINAL 고착력 : "X"방향 6 Kgf 이상
"Y"방향 2 Kgf 이상
6. TERMINAL 도금사양 : PRE-TIN
광택석도금 : 0.8~1.5um 동하지 : 0.5~1.0um

NOTE

1. UNLESS OTHERWISE SPECIFIED ALL RADII TO BE 0.3 RADIOUS
2. MUST BE FREE OF FLASH, SINK AND IMPERFECTION THAT AFFECT FUNCTION.
3. MATING PLUG HOUSING : MG652999
4. THE PRODUCT MUST MEET SPEC' NO. ES-91500
5. TERMINAL RETENSION FORCE: "X" DIRECTION 6 Kgf MIN
"Y" DIRECTION 2 Kgf MIN
6. TERMINAL PLATING SPEC' : PRE-TIN
GROSS TIN PLATE : 0.8~1.5um GROUND BRONZE PLATE : 0.5~1.0um.

NO.	PART NAME	MATERIAL	FINISH	Q'TY
①	040III PCB 4P REC' HS'G (HZT)	PBT	NATURAL	1 EA
②	040III PCB TAB TERMINAL (S)	BRASS	PRE-TIN	4 EA
③	0407 PCB 26P STEEL LOCK	BRASS	PRE-TIN	2 EA



ISSUE MARK

		MATERIAL		SEE TABLE	KET KOREA ELECTRIC TERMINAL CO., LTD.
		FINISH		SEE TABLE	
		WIRE RANGE		CLASS	040III
		INSULATION		TYPE	
△	치수 재정리	SHIN		'05.03.08	PART NO. MG643142
LTR	REVISION RECORD	DR.	CHK.	APP.	
DR.	SHIN '03.11.20	CHK.	SHIN	'03.11.24	PART NAME 040III PCB 4P CONN'T ASS'Y (HZT-PCB LOCK)
CHK.	11/25	APP.			
		TOLERANCE EXCEPT AS NOTED		SEE TABLE	SCALE 2/1